

For Lease

OFFICE/RETAIL - 4,700 Sq. Ft.

4837 N Dixie Highway
Fort Lauderdale, FL

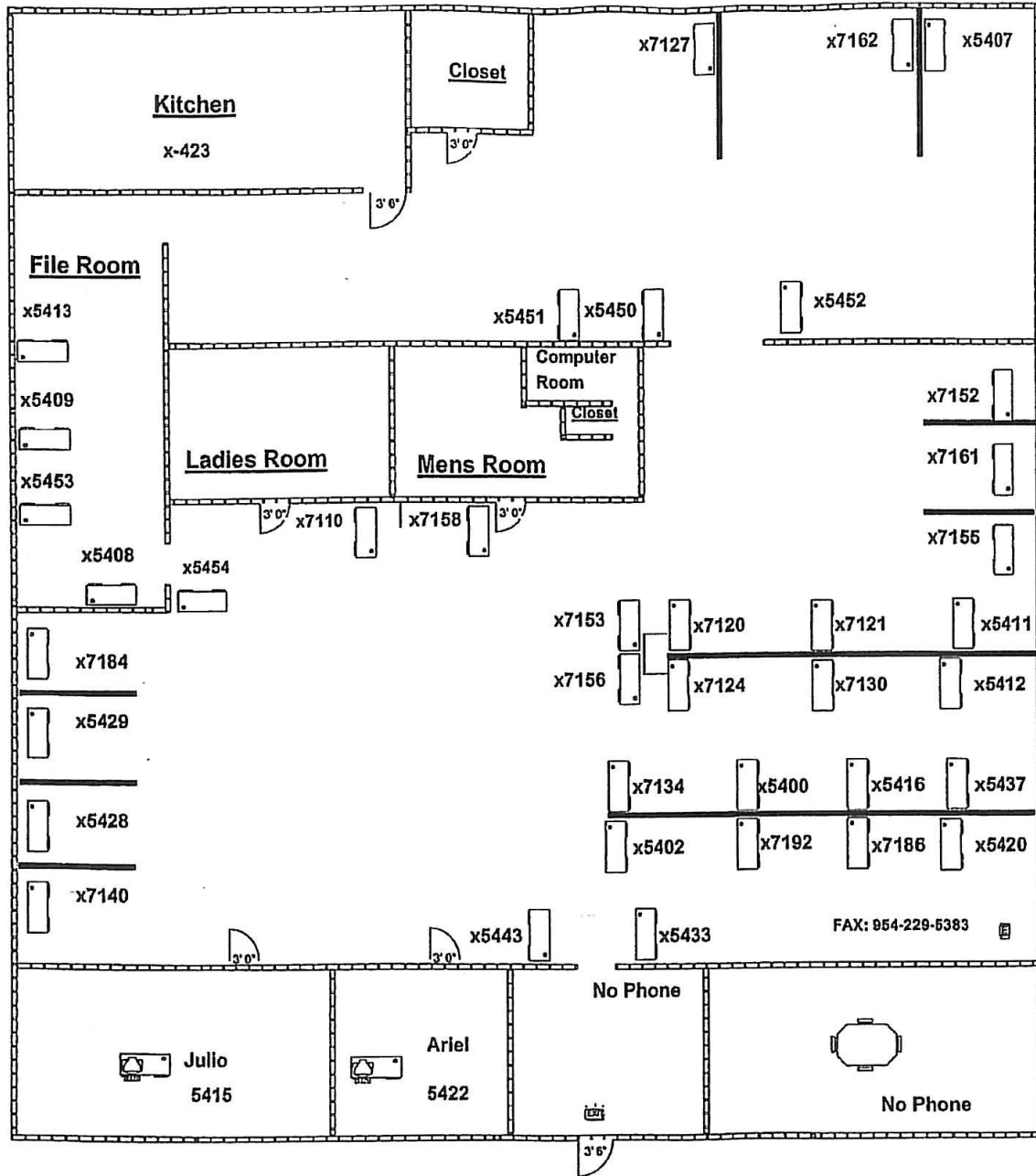

THE FITZGERALD GROUP
COMMERCIAL REAL ESTATE

The Fitzgerald Group | Fort Lauderdale
1800 Eller Drive | Suite 212 | Fort Lauderdale, FL 33316
www.fitzgeraldgroup.com

For Lease Information:

Brad Fitzgerald

O: 954.760.9300

brad@fitzgeraldgroup.com